



- Easy to Use and Learn
- Radiation Safety Protection
- Simple and User-Friendly Operation Interface
- Safe for Film, Chips and Electronic Products.

## Product Introduction

The FSCAN 5030 X-ray inspection equipment is a new security scanning device that utilizes the penetrating power of X-rays to provide rapid, box-free inspection of luggage and belongings. This model is a best-selling product with leading performance parameters, capable of penetrating 40mm steel plates. It features one-button shutdown, automatic detection, energy saving, and environmental protection. It is widely used in public areas such as government agencies, transportation hubs, the logistics sector, courts, prisons, embassies, factories, schools, hospitals, stadiums, and exhibition halls. It is particularly effective in detecting concealed counter-band and flammable/explosive materials (knives, weapons, explosives, fireworks, alcohol/ethanol, etc.) in small items, packages, mail, suitcases, handbags, and backpacks.

## Features

- Modularity: The internal circuit structure adopts a modular design approach. Rational layout design increases the device's interference suppression capacity, ensures stable operation, and simplifies maintenance.
- Digitalization: The hardware system utilizes the latest ASIC fully digital solution design and deep acquisition technology. Compared to analog solutions, it offers high integration, strong interference resistance, and clear imaging effects.
- Comprehensive Functionality: Additional functional modules can be customized according to customer requirements via optional dedicated ports.

For example;

- AI-powered image recognition (hazardous materials warnings)
- Camera integration solutions (person-baggage linking)
- Package barcode association
- UPS power supply

## Functions

Image Processing Functions:

Color/Black and White, Edge Enhancement, High Penetration, Low Penetration, Super Enhancement, Organic Matter Removal, Inorganic Matter Removal (Metallic Appearance Only), Image Inversion, Brightness Enhancement, Darkening, Grayscale Scanning, Zoom, False Color, Image Restoration, Image Saving

System Functions:

Features include: Initial Self-Test, Multi-Level User Management, Image Management, TIP (Threat Image Projection) Management, Curve Diagnosis, Keyboard Diagnosis, Device Information Query, Multi-Format Image Export, OSD (On-Screen Display) Operation, Image Mirroring, 1-64x Seamless Zoom, Magnifier, Operator Training, Precise Image Capture, Tunnel Clearance Reminder, Remote Control Software, One-Touch Shutdown.

### Parameters

Category	Parameter	5030A	5030C
External Dimensions	Tunnel Size	500mm × 300mm (W×H)	500mm × 300mm (W×H)
	Equipment Size	1475mm × 784mm × 1100mm (L×W×H)	1475mm × 784mm × 1100mm (L×W×H)
Performance Parameters	Wire Resolution	AWG38 (+0.102mm)	AWG38 (+0.102mm)
	Spatial Resolution	Horizontal: 1.0mm; Vertical: 1.0mm	Horizontal: 1.0mm; Vertical: 1.0mm
	Penetration Capability	12mm steel plate	40mm steel plate
	X-ray Source	80-100 kV / 0.5 mA	140-160 kV / 0.5-1.25 mA
Radiation Dose	Leakage Dose	<0.5 uSv (at 50mm from casing)	<0.5 uSv (at 50mm from casing)
	Single Scan Dose	<5 µGy/h	<5 µGy/h
Conveyor Parameters	Conveyor Height	660mm (height from ground)	660mm (height from ground)
	Conveyor Speed	22 m/s	22 m/s
Imaging Parameters	Display Size	5 inches	5 inches
	Resolution	1920 x 1080P	1920 x 1080P
General Parameters	Power Consumption	500W	500W
	Power Supply	AC220V 50Hz	AC220V 50Hz
	Noise Level	<55 dB (at 1m distance)	<55 dB (at 1m distance)
	Operating Temperature/Humidity	5°C to 40°C / 10% to 90% non-condensing	5°C to 40°C / 10% to 90% non-condensing
	Storage Temperature/Humidity	-20°C to 40°C / 0% to 90% non-condensing	-20°C to 40°C / 0% to 90% non-condensing
	Equipment Weight	220 kg	245 kg

### Dimensions

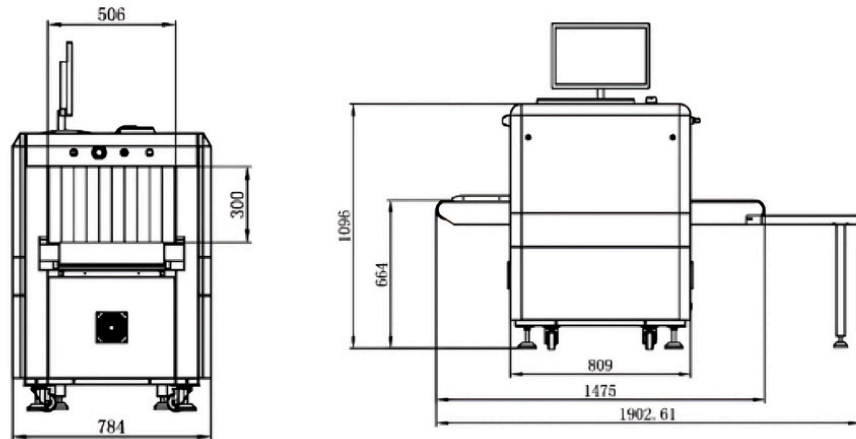

### X-Ray Results

